

MT389

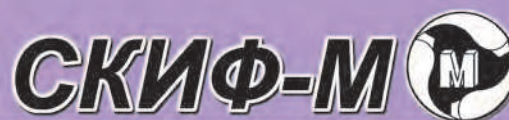

MT389

Отрезные фрезы с СМП



*Основное назначение - отрезные работы и фрезерование узких пазов.
 *Исключительно высокая производительность в связи с повышенной жесткостью конструкции фрез.
 *Тангенциальное крепление СМП с четырьмя эффективными режущими кромками.
 *Высокопроизводительная разрезка деталей из титановых сплавов и нержавеющей стали с использованием СМП SNEX12...T.

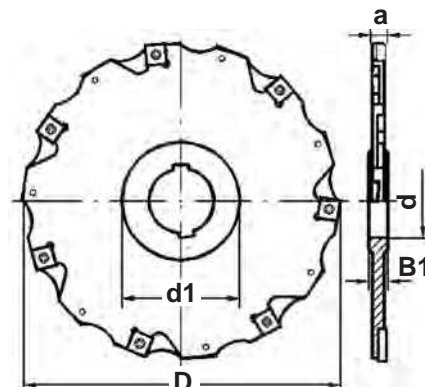

MT389-S...N...SN12-09

Ширина паза 9 мм

Обозначение	Размеры, мм					Z	n _{max} RPM	kg	Кол.	Код	Момент
	D	a	d	d1	B1						
MT389-100S32N05SN12-09	100	9	32	48	12	2x5	7500	0,4	10	T400790-15	7015-T 5,5 Nm
MT389-125S40N06SN12-09	125	9	40	58	12	2x6	6500	0,6			
MT389-160S40N07SN12-09	160	9	40	68	12	2x7	6000	0,9			
MT389-200S50N08SN12-09	200	9	50	72	12	2x8	5000	1,3			
MT389-250S50N11SN12-09	250	9	50	72	12	2x11	4500	1,9			

MT389-S...N...SN12-10

Ширина паза 10 мм

MT389-100S32N05SN12-10	100	10	32	48	12	2x5	7500	0,4	10	T400890-15	7015-T 5,5 Nm
MT389-125S40N06SN12-10	125	10	40	58	12	2x6	6500	0,6			
MT389-160S40N07SN12-10	160	10	40	68	12	2x7	6000	0,9			
MT389-200S50N08SN12-10	200	10	50	72	12	2x8	5000	1,3			
MT389-250S50N11SN12-10	250	10	50	72	12	2x11	4500	2,0			
MT389-315S50N13SN12-10	315	10	50	72	12	2x13	4500	6,0			
MT389-400S50N17SN12-10	400	10	50	72	12	2x17	4500	8,0			
MT389-510S80N24SN12-10	513	10	80	240	12	2x24	3000	12,4			
MT389-630S80N30SN12-10	630	10	80	240	12	2x30	2500	19,0			
MT389-800S80N27SN12-10	800	10	80	240	12	2x27	1600	19,0			
MT389-1010S120N34SN12-10	1010	10	120	240	12	2x34	625	19,0			

MT389-S...N...SN12-11

Ширина паза 11 мм

MT389-100S32N03SN12-11	100	11	32	48	14	3x3	7500	0,4	9	T400890-15	7015-T 5,5 Nm
MT389-125S40N04SN12-11	125	11	40	58	14	3x4	6500	0,6			
MT389-160S40N05SN12-11	160	11	40	68	14	3x5	6000	0,9			
MT389-200S50N05SN12-11	200	11	50	72	14	3x5	5000	1,4			
MT389-250S50N07SN12-11	250	11	50	72	14	3x7	4500	2,0			

MT389-S...N...SN12-12

Ширина паза 12 мм

MT389-100S32N03SN12-12	100	12	32	48	14	3x3	7500	0,4	9	T400890-15	7015-T 5,5 Nm
MT389-125S40N04SN12-12	125	12	40	58	14	3x4	6500	0,6			
MT389-160S40N05SN12-12	160	12	40	68	14	3x5	6000	0,9			
MT389-200S50N05SN12-12	200	12	50	72	14	3x5	5000	1,4			
MT389-250S50N07SN12-12	250	12	50	72	14	3x7	4500	2,1			